

BOILER 1-4K PIPE BEVELLER 1" to 4"

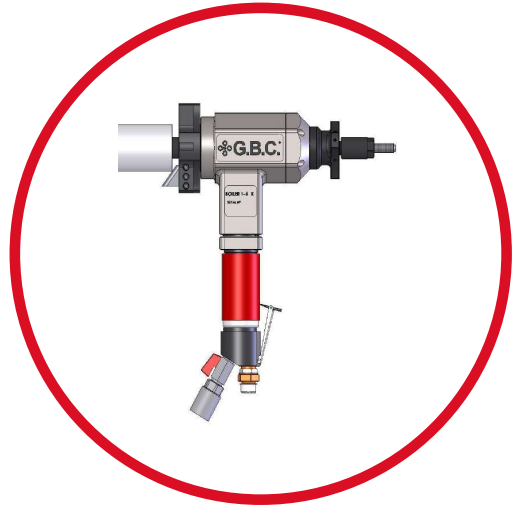
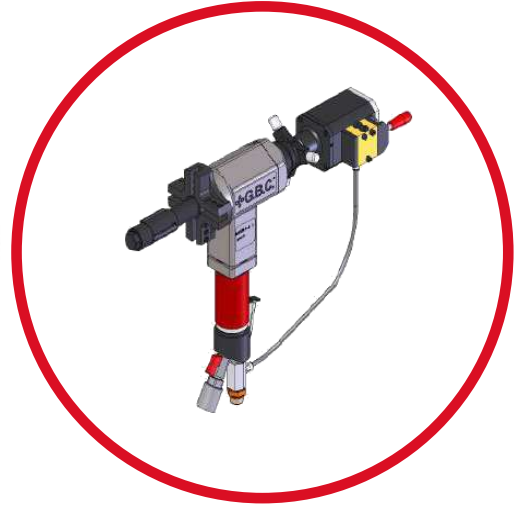

GBC BOILER 1-4K

portable pipe bevelling machine

RANGE: 23 to 112mm i/d

- * **Functions:** External Bevelling
Internal Bevelling
Elbow Bevelling
Facing
Counter-Boring
Weld Removal
Membrane Wall Removal
J-Prepping - Pipe
J-Prepping - Tubeplate
- * **Materials:** Any kind of steel
Exotic Alloys
- * **Power:** Pneumatic / Electric (110v or 220v) / Battery
- * **Warranty:** 2 years



The BOILER 1-4K is one of our most popular i/d locking, end prep machine. Its power to weight ratio makes it favoured by operators in every industry.

The 4 jaw (offset) toolholder enables simultaneous external, internal bevelling and facing - particularly useful for high volume, repetitive applications.

The BOILER 1-4K utilises a wide range of tooling. These can be either HSS, TiCn coated or Tungsten Carbide. Whether the tube is mild steel, stainless steel, exotic materials, clad or heavy wall, appropriate tooling is available. Holders for carbide inserts are also available.

The BOILER1-4 K features the GBC 3 Jaw Locking System which simultaneously centres and locks the machine in the pipe. Recognised as the superior locking system it has been copied the world over.

This machine, like all GBC machines, is torque reactive meaning the pipe to be prepped does not have to be fixed. A useful feature for on site maintenance and repair situations.

GBC machines are supported by a global network of stockists and repair centres.



POWER OPTIONS & ACCESSORIES

PNEUMATIC



ELECTRIC

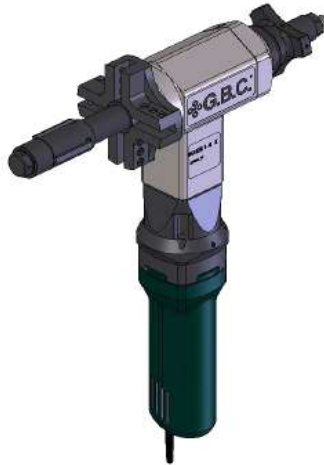

BATTERY



AUTOLOCK



AUTOMATIC



PACKAGE

All units are supplied complete with all locking jaws to cover the full range of the machine.

The package includes:
Instruction manual, Warranty Certificate, CE Certificate, machine drawings, parts list, service tools and a selection of tools.
All supplied in a metal carrycase.

80mm Chuck



Thin Wall Jaws



Elbow Shafts



Filter Lubricator



TECHNICAL SPECIFICATIONS

DESCRIPTION	MEASUREMENT	PNEUMATIC	ELECTRIC	BATTERY
Part Number		BO14P	BO14E	BO14E008
Locking tube range	mm (i/d.)	23 - 112	23 - 112	23 - 112
Working range	inch (o/d.)	1 - 4"	1 - 4"	1 - 4"
Idle speed	rpm	0 - 87	74	44
Torque	Nm	82	124	116
Length of axial feed	mm	40	40	40
Max acoustic emissions	dB	75	75	75
Pneumatic motor power	hp	1.33		
Air consumption	cfm	35		
Air working pressure	psi	90		
Hose connection	inches	1/2"		
Electric motor power	watt		1300	720
Voltage	volt		110 / 220	battery - 18V 4.0Ah
Frequency	Hz		50 / 60	charger 50 / 60
Unit weight	kg	9.0	10.0	10.0
Packing dimensions	mm	640 x 640 x 150	640 x 640 x 150	640 x 640 x 150
Packing weight	kg	28.5	29.5	29.5

DIMENSIONS

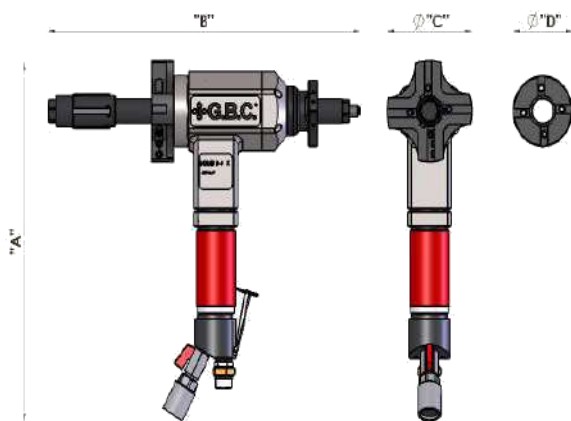

DIM	PNEUMATIC	ELECTRIC	BATTERY
A	410mm	450mm	457mm
B	425mm	425mm	425mm
C	115mm	115mm	115mm
Ø D (opt)	80mm	80mm	80mm

EXAMPLES OF TOOLING

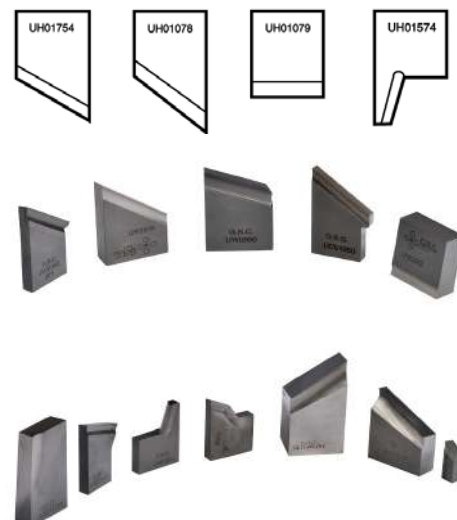

All units are supplied complete with all gripping segments to cover the full range of the machine. Service tools, drawings, instruction manual and warranty certificate are also supplied as standard. Each machine is supplied with a protective metal carrying case. We strongly recommend the use of the GBC portable filter lubricator with all our pneumatic models.